



# SIL-GL

Guideline for the use of IEC 61508 and IEC 61511  
in the offshore industry

## Tor Onshus

Engineering Cybernetics

Norwegian Institute of Science and Technology (NTNU)

tlf: 73594388

fax: 73594399

Tor.Onshus@itk.ntnu.no

[http://www.itk.ntnu.no/ansatte/Onshus\\_Tor](http://www.itk.ntnu.no/ansatte/Onshus_Tor)



# Background

- **IEC 61508 widely accepted as the basis for**
  - design
  - specification
  - contract
  - performance standard
- **The Norwegian Petroleum Directorate (NPD) recommend the use of IEC 61508**
  - performance requirement stating minimum SIL



## Experience

-using IEC 61508

- **Difficult in a development project**
  - Extensive work
  - Variable SIL for same functions and risk due to
    - methodology (risk graph/matrix, PFD figures)
    - persons/organsations
- **Does not preserve good solutions**
  - How to identify necessary safety functions?



## Does QRA give required SIL?

- **Quantitative Risk Analysis (QRA) of today does **not** give required SIL**
  - Risk Analysis in 61508 is not QRA of today
  - Not all safety functions are modelled in QRA
  - Historical data includes a safety system
  - Demand rate for functions not known

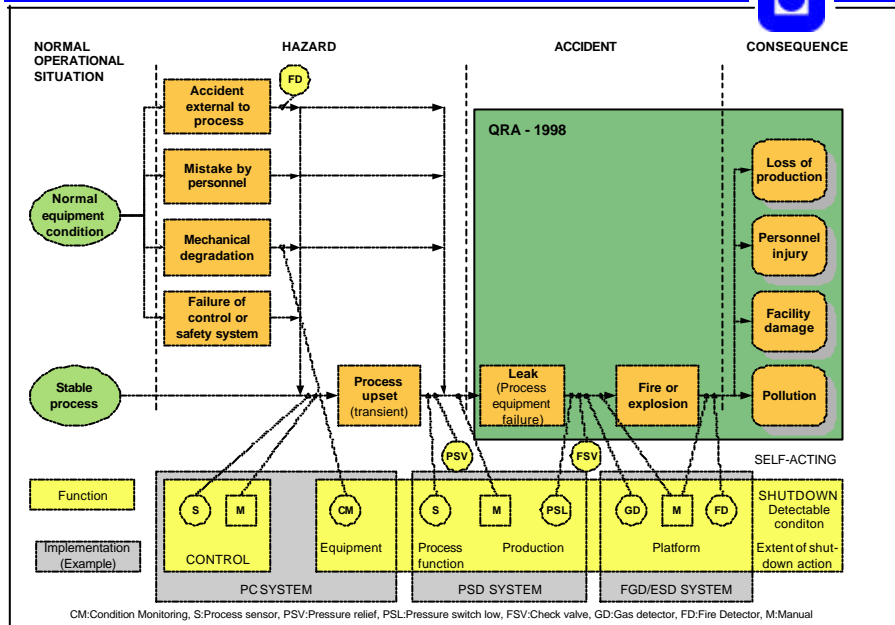

## Scope of Work

### -SIL-GL workgroup

- Develop a first version of a Guideline
  - Help in the use of 61508 & 61511
  - Give minimum SIL levels
  - Give guidance on design
- The intention is that this later will become a Norsok standard



## Field of Application for GL

- In the petroleum industries where the NPD regulations apply
- Applies to the following functions:
  - Process sectionalisation
  - Fire detection
  - Gas detection
  - Electric isolation
  - Start and stop of fire pumps
  - Active fire fighting
  - Active smoke control
  - Process protection
  - Isolation of wells and riser
  - Blow-down



## Limitations with SIL methods

- Different users can come up with different SIL for the same safety function, applying methods
- Lack of reliability data for specific equipment and operations
- Lack of data for demand rates for the different safety functions
- The use of methods for global safety functions seem to cause considerable problems
  - Demands due to many scenarios



## Approach

- Not risk based pr. installation
- Two categories
  - Local functions (typically PSD)
  - Global functions (typically ESD and FG)
- Minimum SIL for selected safety functions
  - ensure a minimum safety level
  - standardisation across the industry
  - avoid time consuming calculations



## SIL requirements based on

- Current best practice referred to SIL
  - In practice the same for “all” installations
- What is necessary?
  - SIL 1: Fails every 10 demands
- Available generic reliability-data
- What is possible with today’s technology.



## Local safety functions

- EUC typically a pressure vessel
- Function defined by API RP 14C
- Usually implemented by
  - PSD as first barrier
  - Mechanical device as second barrier



## Minimum SIL requirement

-local safety function

<b>FUNCTION</b>	<b>SIL</b>
PSHH, LSHH	1
LSHH, KO drum	2
TSHH/TSLL	1
PSLL (leak detection)	0



## Global safety functions

- EUC typically a geographical area
- Systems and Functions defined by NPD
- Definition of success criteria is important
  - Gas detection
    - When there is gas in the area
    - When the detector is exposed to gas
  - Segregation & Blow down
    - Total function
    - Pr. single valve (basic function)
- QRA to sum up basic functions

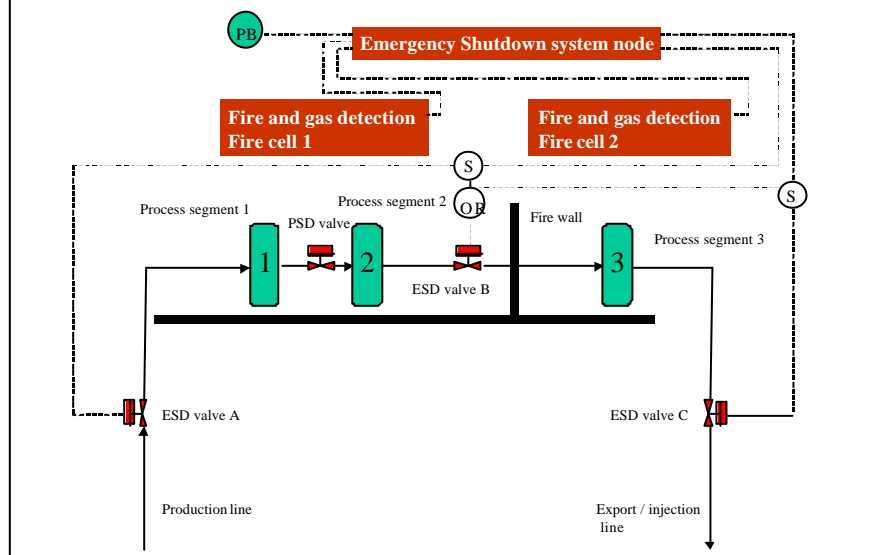



## Minimum SIL requirement

-global safety function

<b>FUNCTION</b>	<b>SIL</b>
Process segregation, pr. valve	2
Depressurisation, pr. valve	2
Well isolation, sigle well	3
Flowline isolation	2
Fire & Gas detection	2
Electric isolation	2
Deluge	1



## Handling of deviations

- Non conventional design
  - HIPPS instead of PSV capacity
  - Technology not proven
  - Safety interlock systems
- Less than min. SIL is claimed
  - This installation is less dangerous
- Hazard higher than “normal”
  - Special hazards (identified in FES?)

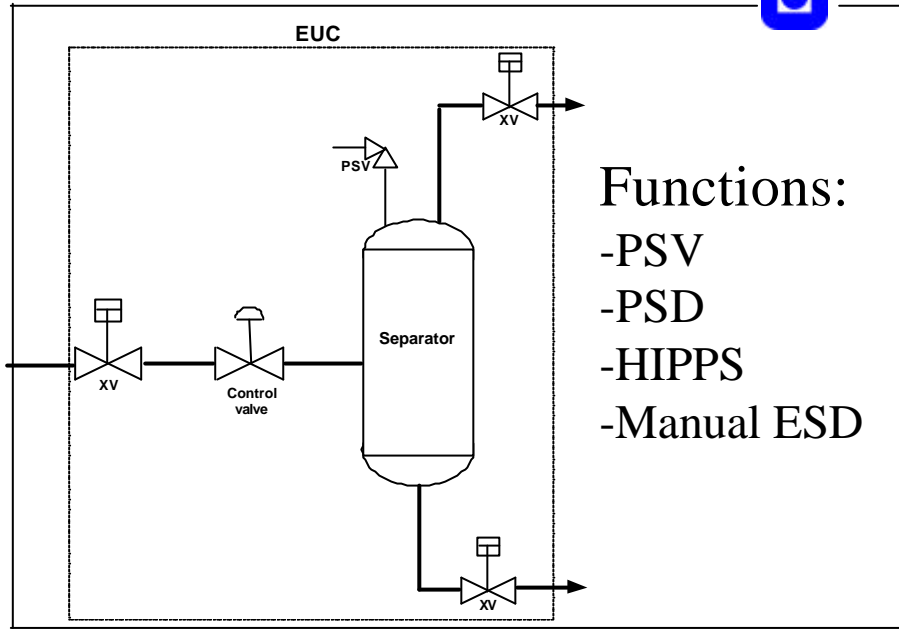

- Functions:
- PSV
  - PSD
  - HIPPS
  - Manual ESD



# SIL Allocation

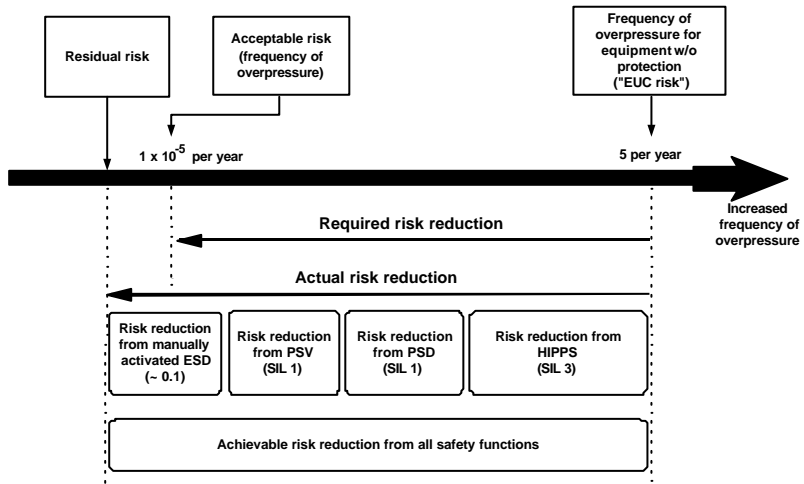



## IEC 61508 does not solve everything

- Production regularity
  - Focus on personnel safety
- Vulnerability of common components for many safety functions
- No detailed requirements to "non-E/E/PES equipment"
- Accepted risk



## QRA & SIL-GL

- Today (NPD: high reliability)
  - QRA anticipate a "SIL"
  - Is there a connection between QRA and "SIL"?
  - Is "SIL" maintained?
- Tomorrow (SIL-GL: specified SIL)
  - PFD of functions defined prior to QRA
  - SIL of function is fulfilled



## Summary

- IEC 61508 gives a good framework
  - Risk based approach is difficult
- SIL-GL
  - Reduce cost
  - Give a common safety level
  - Preserve good design
- Only real use can show the benefits